



COMBiLiFT

Customised Handling Solutions

C4000 Electric

making short work of long loads



forward/reverse mode



carousel mode



sideward mode



three machines in one

> counterbalance forklift > sideloader > aisle truck



SPECIFICATIONS

Model C4000 E

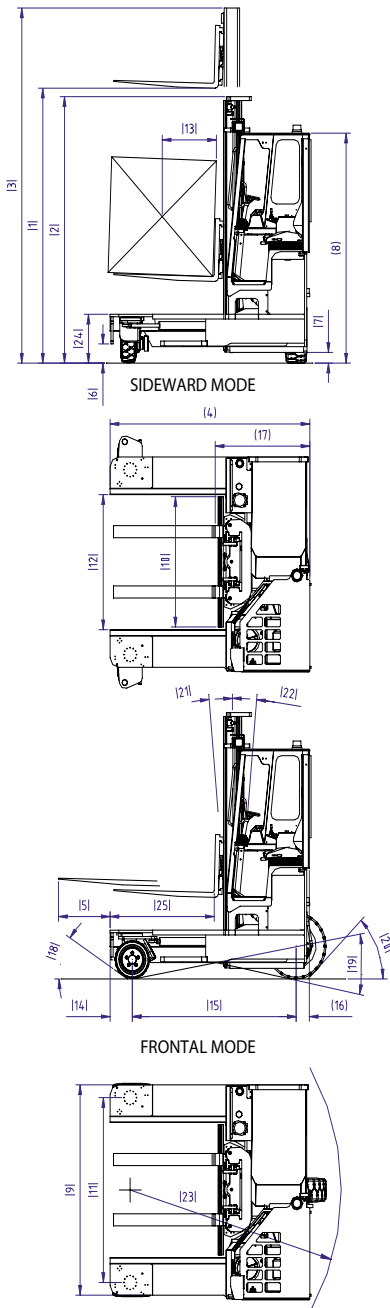

REF	DESCRIPTION	C4000E
1a	Max. Lift Height	4040mm
1b	Free Lift Height	0mm
2	Height Mast Closed	2855mm
3	Max.(Mast raised)	5095mm
4	Overall Length	2300mm
5	Mast Travel	1250mm
6	Ground Clearance Under Mast	150mm
7	Ground Clearance to Centre of Wheelbase	120mm
8	Height Over Cab (without work-lights)	2435mm
9	Width	2190mm
10	Outside Spread of Fork Arms	1350mm
11	Track Front	1980mm
12	Frame Opening	1400mm
13	Load Centre Distance	600mm
14	Overhang Front	245mm
15	Wheel Base	1915mm
16	Overhang Back	140mm
17	Length From Face of Fork	1100mm
18	Approach Angle	45°
19	Ramp Angle	17°
20	Departure Angle	45°
21	Forward Tilt	3°
22	Backward Tilt	5°
23	Minimum Outside Radius	2390mm
24	Platform Height	495mm
25	Platform Length	1200mm
A	Capacity	4000Kg
B	Unladen Weight	6800Kg
C	Maximum Ground Speed	10 km/h
D	Gradability	10%
E	Battery Capacity (V / Ah)	80V / 625 Ah
F	Fork Section	50 x 125 x 1200mm
G	16 x 7 – 10.5 Front Tyre (Solid)	OD 406 / Width 178mm
H	27 x 10 - 12 Rear Tyre (Super Elastic)	OD 680 / Width 255mm
I	Standard Colour	Green and Grey
J	Suspension Seat	KAB Model 116



The C4000E has a single rear wheel providing excellent manoeuvrability.



The hydraulic pump connected to the electric motor powers the drive wheels and the hydraulic functions.



The operator compartment on the C4000 Electric.



The battery compartment on the C4000 Electric.

FEATURES INCLUDE:

- Rubber Mounted Half Cabin with Top, Front, Side and rear Glass
- Multi-Direction Operation
- 2 Wheel Hydrostatic Drive
- Capability of Operating Outdoor as well as indoor
- Load Sensing Steering
- 4 Way lever Positioning of Wheels

Distributed by

www.COMBiLiFT.COM

Combilift Ltd., Co. Monaghan, Ireland

Tel: +353 47 80500

Fax: +353 47 80501

info@combilift.com

COMBiLiFT has a policy of continuous product development and reserves the right to alter specifications without prior notice. Specifications and / or dimensions may vary from those illustrated in some countries.